

2018

SCIENCE
LANCET
MISCELLANEOUS

AEROCATCH FASTENERS



AeroCatch® are aerodynamic, low profile bonnet pins and panel fasteners setting new standards in the 21st century. Providing a wide variety of fixing solutions for Motorsport, Specialist Vehicles, Marine & Transportation. AeroCatch® bonnet pins are manufactured in England and distributed worldwide.



AeroCatch
Designed for BONNET, BOOT, HOOD, TRUNK, TAILGATE, Suitable for STREET, RACE & RALLY. Available in BLACK, WHITE or CARBON LOOK finish. LOCKING or NON-LOCKING.
Kit contains: 2 x AeroCatch Bodies, 2 x Nut Fixing Plates, 2 x Red Aluminium Strikes, 2 x Rubber Bump Stops, 2 x Key Sets, 1 x Fastener Kit, 1 x Arrow Sticker Set, 1 x AeroCatch Cardboard Template



Code	Mounting	Lock	Colour
120-2000	On top of the panel	No	Black
120-2100	On top of the panel	Yes	Black
120-3000	On top of the panel	No	Carbon look
120-3100	On top of the panel	Yes	Carbon look
125-2000	Underneath the panel	No	Black
125-2100	Underneath the panel	Yes	Black
125-3000	Underneath the panel	No	Carbon look
125-3100	Underneath the panel	Yes	Carbon look



AeroCatch 2
AeroCatch 2 was developed initially for off-shore racing powerboats to secure engine covers and hatches. Flush fitting eliminates any potential trip hazards on deck and provides panel security. Available in Plus and Plus flush version. Black or white color.



Code	Mounting	Lock	Colour
220-2000	On top of the panel	No	Black
225-2000	Underneath the panel	No	Black



AeroCatch 3
Designed to secure BODY PANELS, BUMPERS, TEMPORARY WALLS. Ideal for QUICK RELEASE & ASSEMBLY. Available in PLUS FLUSH or FLUSH style



Code	Mounting	Lock	Colour
320-2000	On top of the panel	No	All black
325-2000	Underneath the panel	No	All black



AeroCatch 3 XS
Compact, high strength tension latch for drawing together panels with the added feature of a shear engagement tongue which allows the latch to carry loads in 3 axes. The quick release function with secondary lock and hold-out handle make panel assembly and disassembly simple. The compact design and simple installation make it ideal for fitting into a preformed pocket. It's our smallest yet!

Key Features

- Above Panel / Pocket Mounting
- Small compact design
- Shear and tension latch carries loads in 3 axes
- Lightweight hard anodised aluminium
- Hold-out handle
- Aerodynamic
- Simple release with secondary lock
- Factory set tension

- Above Panel / Pocket Mounting
- Small compact design
- Shear and tension latch carries loads in 3 axes
- Lightweight hard anodised aluminium
- Hold-out handle
- Aerodynamic
- Simple release with secondary lock
- Factory set tension



Code	Mounting	Lock	Colour
350-2000	On top of the panel	No	Black



AeroCatch Xtreme
With the same features of AeroCatch version, but with steel strikes ... at the same price. Lock or un-lock version, flush or plus flush mounting (below or above the panel). Black color



Code	Mounting	Lock	Colour
120-4000	On top of the panel	No	Black
120-4100	On top of the panel	Yes	Black
125-4000	Underneath the panel	No	Black
125-4100	Underneath the panel	Yes	Black





Camloc Quarter Turns

- Safe Mechanical Fastener System
- Locking Or Unlocking By Quarter Turn
- Long Life - High Number Of Operating Cycles
- Quarter Turn Slotted Head Fastener
- Hand Or Tool Operated
- Service Friendly - Time Saving And Cost Cutting
- Vibration Resistant



Code	Type	Total length	Wall thickness
212-12	Receptacle	-	-
2600LW	Retaining washer	-	-
V26S01-10AGV	Fastener	26,00 mm	7,60 - 8,40 mm
V26S01-11AGV	Fastener	27,00 mm	8,40 - 9,15 mm
V26S01-12AGV	Fastener	27,90 mm	9,15 - 9,90 mm
V26S01-13AGV	Fastener	28,90 mm	9,90 - 10,65 mm
V26S01-14AGV	Fastener	29,40 mm	10,65 - 11,40 mm
V26S01-15AGV	Fastener	30,25 mm	11,40 - 12,20 mm
V26S01-16AGV	Fastener	31,05 mm	12,20 - 12,95 mm
V26S01-17AGV	Fastener	31,75 mm	12,95 - 13,70 mm
V26S01-18AGV	Fastener	32,20 mm	13,70 - 14,50 mm
V26S01-19AGV	Fastener	33,10 mm	14,50 - 15,25 mm
V26S01-1AGV	Fastener	19,60 mm	0,75 - 1,50 mm
V26S01-20AGV	Fastener	35,25 mm	15,25 - 16,00 mm
V26S01-2AGV	Fastener	20,20 mm	1,50 - 2,30 mm
V26S01-3AGV	Fastener	20,95 mm	2,30 - 3,05 mm
V26S01-4AGV	Fastener	21,90 mm	3,05 - 3,80 mm
V26S01-5AGV	Fastener	22,50 mm	3,80 - 4,60 mm
V26S01-6AGV	Fastener	23,30 mm	4,60 - 5,35 mm
V26S01-7AGV	Fastener	24,05 mm	5,35 - 6,10 mm
V26S01-8AGV	Fastener	24,90 mm	6,10 - 6,85 mm
V26S01-9AGV	Fastener	25,60 mm	6,85 - 7,60 mm



Dzus Quarter Turns

Designed for use on curved or contoured surfaces where ejection of the fastener is essential to remove the top panel. The ejecting mechanism also gives an instant signal that the fastener is unlocked. This Dzus Fastener has a flush head and is made of zinc plated mild steel.

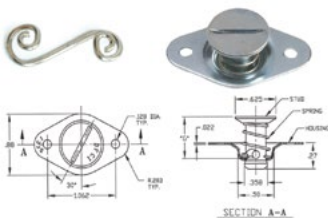

Code	Type	Total length	Wall thickness
EHF5-40	Fastener	13 mm	3 mm
EHF5-45	Fastener	15 mm	4 mm
EHF5-50	Fastener	16 mm	5 mm
EHF5-55	Fastener	17 mm	6 mm
EHF5-60	Fastener	18,5 mm	8 mm
EHF5-65	Fastener	19,8 mm	9 mm
EHF5-70	Fastener	21 mm	11 mm
EHF5-80	Fastener	23,6 mm	14 mm
S5-300	Fastener Attachment Spring	-	-



Pip Pins

The Pip Pins are suitable for most applications where quick access is necessary. For use on body panels, engine covers and nose cones.

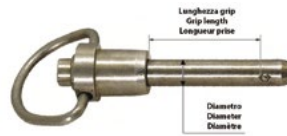

Code	Diameter	Grip length
800216	1/4"	0.50"
800217	1/4"	0.75"
800218	1/4"	1.00"
800219	1/4"	1.25"
800220	1/4"	1.50"
800221	1/4"	1.75"
800222	1/4"	2.00"
800224	1/4"	2.50"
800225	1/4"	3.00"
800227	1/4"	4.00"
800232	5/16"	0.50"
800233	5/16"	0.75"
800234	5/16"	1.00"
800235	5/16"	1.25"
800236	5/16"	1.50"
800237	5/16"	1.75"
800238	5/16"	2.00"
800240	5/16"	2.50"
800241	5/16"	3.00"
800243	5/16"	4.00"
800248	3/8"	0.50"
800249	3/8"	0.75"
800250	3/8"	1.00"
800251	3/8"	1.25"
800252	3/8"	1.50"
800253	3/8"	1.75"
800254	3/8"	2.00"
800256	3/8"	2.50"
800257	3/8"	3.00"
800259	3/8"	4.00"



Terry Spring Clips



Code	Description
TER-CLI	Terry spring
TER-HOC	Terry spring hook



Slide Latch



Code	Description
1500	Slide latch
150003	Slide latch bush



Quick Release Bonnet Pins

Aluminum or steel (heavy duty) quick release bonnet pins with thread 7/16UNF or M12x1.50 (sold in pairs).



Code	Thread	Material	Colour
GE58	M12x1.50	steel	steel
GS001	7/16 UNF	aluminium	gold
GS002	7/16 UNF	aluminium	blue
GS003	7/16 UNF	aluminium	red
GS004	7/16 UNF	steel	steel



Universal Joints

Universal joint for use in racing with a very high load resistance. It features a rubber boot that protects the joint from dust, increasing longevity. This coupling can be used as a joint of gear control, starter, steering box, etc. ...



Code	Inner Ø	Outer Ø
UJ174	12,70 mm	15,75 mm
UJ274	15,88 mm	18,92 mm
UJ374	19,05 mm	22,10 mm
UJ474	20,62 mm	25,27 mm



NAS washers



Code	For bolt	Thickness
AN960-10	10-32 UNF	1,6 mm
AN960-10L	10-32 UNF	0,8 mm
AN960-416	1/4" x 28 UNF	1,6 mm
AN960-416L	1/4" x 28 UNF	0,8 mm
AN960-516	5/16" x 24 UNF	1,6 mm
AN960-516L	5/16" x 24 UNF	0,8 mm
AN960-616	3/8" x 24 UNF	1,6 mm
AN960-616L	3/8" x 24 UNF	0,8 mm
AN960-716	7/16" x 24 UNF	1,6 mm
AN960-716L	7/16" x 24 UNF	0,8 mm

ADVANCE
Racing Tape

Easy to unroll and tear, good abrasion resistance and outdoor exposure. Excellent resistance to water. Writable surface with a glossy finish. Width 50mm, length 50m

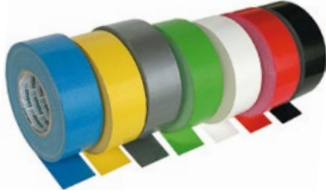

Code	Colour
AT0175-AZ	Blue
AT0175-BI	White
AT0175-GI	Yellow
AT0175-GR	Gray
AT0175-NE	Black
AT0175-RO	Red
AT0175-VE	Green

3M
Aluminium foil tape

Aluminum tapes of different thicknesses for each type of application, flame resistant, excellent sealants.



Code	Roll	Brand	Thickness/weight
AT0500	50 mm x 55 m	Advance	0,08 mm
HOGLA-100	100 mm x 33,5 m	Hogla	150g/m ²
HOGLA-50	50 mm x 33,5 m	Hogla	150g/m ²
3M42550	50 mm x 55 m	3M	0,12 mm

GIEFFE RACING DISTRIBUTED
Helicopter Tape

Gloss clear polyurethane anti-erosion Helicopter tape, thickness 0.20 mm, available in rolls 25, 50 e 100 mm x 33mt. Ideal for protecting the body.



Code	Roll
MOMHELTAPE2533	25 mm x 33 m
MOMHELTAPE5033	50 mm x 33 m
MOMHELTAPE10033	100 mm x 33 m

PVC Tape

The tape PVC10-mil is designed to protect the surface on which it is applied by rubbing, erosion. Usually used for the protection of tanks.



Codice	Roll
SCAPA50	50 mm x 33 m

Thomas&Betts
TY-Rap ties

Cable Tie 50lb 7" Ultraviolet Resistant Black Nylon with Stainless Steel Locking Device Bulk. In pack of 100 pcs.



Code	Grip length	Width
TY232MX	203 mm	2,4 mm
TY234MX	356 mm	2,4 mm
TY23MX	92 mm	2,4 mm
TY242MX	208 mm	3,6 mm
TY244MX	368 mm	3,6 mm
TY24MX	140 mm	3,6 mm
TY253MX	290 mm	4,8 mm
TY25MX	186 mm	4,8 mm
TY26MX	284 mm	3,6 mm
TY28MX	360 mm	4,8 mm
TY29MX	771 mm	6,9 mm

Thomas&Betts
TY-Rap mounting cases

Nylon or metal supports for the fastening of the ties.



Code	Type
TC102	1
TC104	4
TC105	3
TC141	2

Araldite
Cement



Code	Type
AR-RA-S	Rapid (24 ml syringe)
AR-ST	Ultra (24 ml syringe)

GIEFFE RACING DISTRIBUTED
Aerospace Locknut (K-Nut)

Precision formed Hexagon nuts, also referred to as 6-point nuts, in wrenchable format and offer tremendous versatility for design and functional requirements. All of these Nuts are small, lightweight, self locking and have an extremely high tensile strength.



GIEFFE RACING DISTRIBUTED
Nuts



Code	Thread	Hand
CD1/2LH	1/2" x 20 UNF	Left
CD1/2RH	1/2" x 20 UNF	Right
CD1/4LH	1/4" x 28 UNF	Left
CD1/4RH	1/4" x 28 UNF	Right
CD3/4LH	3/4" x 16 UNF	Left
CD3/4RH	3/4" x 16 UNF	Right
CD3/8LH	3/8" x 24 UNF	Left
CD3/8RH	3/8" x 24 UNF	Right
CD5/16LH	5/16" x 24 UNF	Left
CD5/16RH	5/16" x 24 UNF	Right
CD5/8LH	5/8" x 18 UNF	Left
CD5/8RH	5/8" x 18 UNF	Right
CD7/16LH	7/16" x 20 UNF	Left
CD7/16RH	7/16" x 20 UNF	Right
DADO-M6X1DXNC	M 06 x 1 mm	Right
DADO-M6X1SXNC	M 06 x 1 mm	Left
DADO-M8X1DXNC	M 08 x 1 mm	Right
DADO-M8X1SXNC	M 08 x 1 mm	Left
DADO-M8X1.25DXNC	M 08 x 1,25 mm	Right
DADO-M8X1.25SXNC	M 08 x 1,25 mm	Left
DADO-M10X1DXNC	M 10 x 1 mm	Right
DADO-M10X1SXNC	M 10 x 1 mm	Left
DADO-M10X1.25DXNC	M 10 x 1,25 mm	Right
DADO-M10X1.25SXNC	M 10 x 1,25 mm	Left
DADO-M10X1.5DXNC	M 10 x 1,5 mm	Right
DADO-M10X1.5SXNC	M 10 x 1,5 mm	Left
DADO-M12X1.25DXNC	M 12 x 1,25 mm	Right
DADO-M12X1.25SXNC	M 12 x 1,25 mm	Left
DADO-M12X1.5DXNC	M 12 x 1,5 mm	Right
DADO-M12X1.5SXNC	M 12 x 1,5 mm	Left
DADO-M12X1.75DXNC	M 12 x 1,75 mm	Right
DADO-M12X1.75SXNC	M 12 x 1,75 mm	Left
DADO-M14X1.5DXNC	M 14 x 1,5 mm	Right
DADO-M14X1.5SXNC	M 14 x 1,5 mm	Left
DADO-M14X2DXNC	M 14 x 2 mm	Right
DADO-M14X2SXNC	M 14 x 2 mm	Left
DADO-M16X1.5DXNC	M 16 x 1,5 mm	Right
DADO-M16X1.5SXNC	M 16 x 1,5 mm	Left
DADO-M18X1.5DXNC	M 18 x 1,5 mm	Right
DADO-M18X1.5SXNC	M 18 x 1,5 mm	Left
DADO-M20X1.5DXNC	M 20 x 1,5 mm	Right

Code	Thread
K-1/2UNF	1/2" UNF
K-1/4UNF	1/4" UNF
K-3/8UNF	3/8" UNF
K-5/16UNF	5/16" UNF
K-5/8UNF	5/8" UNF
K-7/16UNF	7/16" UNF

Aerospace locknuts (K-NUTs) with metric thread are available in a version CADMIUM FREE. See the specific model of the Blue Fast line by KL-projects.



BlueFast.
by KL-PROJECTS

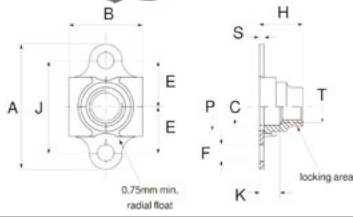

Floating Anchor Nut Cadmium Free

BlueFast Floating anchor nuts free of cadmium and chrome IV
In 25CD4 / C45 steel, zinc-nickel finish with trivalent chromium treatment and MoS2 (molybdenum disulfide) layer.
Identifiable by the Blue Dot. Hardness max 44 HRC. Self locking - 1100 MPa - 235 ° C.
Performance compliant with LN65016 standard.

Code	Thread T	A max	B max	C ± 0.05	E ± 0.1	F	J ± 0.05	H max	K min	P min	S max	Weight (-)
BFAFL2AM03050	M3 x 10.5	23.2	10.6	-	8.5	2.5	17.0	3.2	-	4.5	0.7	1.5 g
BFAFL2AM04070	M4 x 0.7	23.2	10.6	4.2	8.5	2.5	17.0	5.2	1.6	5.5	0.7	1.7 g
BFAFL2AM05080	M5 x 0.8	25.2	11.0	5.2	9.5	2.5	19.0	6.2	1.6	6.5	0.7	1.9 g
BFAFL2AM06100	M6 x 1.0	29.2	13.1	6.2	11.0	3.3	22.0	7.2	1.6	7.5	0.7	3.3 g
BFAFL2AM08100	M8 x 1,0	33.2	15.5	8.4	13.0	3.3	26.0	8.2	1.6	9.5	0.85	6.3 g
BFAFL2AM08125	M8 x 1.25	33.2	15.5	8.4	13.0	3.3	26.0	8.2	1.6	9.5	0.85	6.3 g
BFAFL2AM10125	M10 x 1.25	41.0	17.3	10.4	16.0	3.3	32.0	9.9	1.6	11.5	1.0	9.5 g
BFAFL2AM10150	M10 x 1.5	41.0	17.3	10.4	16.0	3.3	32.00	9.9	1.6	11.5	1.0	9.5 g



BlueFast.
by KL-PROJECTS

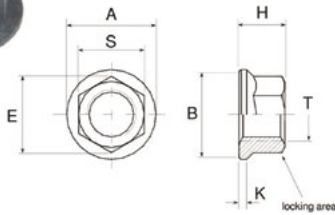

K-Nuts cadmium free

BlueFast K-Nuts free of cadmium & chrome VI.

Code	Thread	A max	B min	E min	S	H max	K min	Weight (-)
BFKHEXAM03050	M3 x 0.5	6	4.9	4.4	4 H13	3.0	0.5	0.28 g
BFKHEXAM04070	M4 x 0,7	8	6.5	5.5	5 H13	4.0	0.6	0.50 g
BFKHEXAM05080	M5 x 0,8	9.2	8	6.7	5 H13	5.0	0.6	0.80 g
BFKHEXAM06100	M6 x 1,0	10.5	9.4	7.8	7 H13	5.4	0.9	1.15 g
BFKHEXAM07100	M7 x 1,0	12.6	11.3	8.9	8 H13	6.2	1.0	1.17 g
BFKHEXAM08100	M8 x 1,0	13.6	12.3	11.1	10 H13	7.2	1.1	3.1 g
BFKHEXAM08125	M8 x 1,25	13.6	12.3	11.1	10 H13	7.2	1.1	3.1 g
BFKHEXAM09100	M9 x 1,0	16.6	15.2	13.3	12 H13	8.5	1.3	5 g
BFKHEXAM10100	M10 x 1,0	16.6	15.2	13.3	12 H13	8.5	1.3	4.5 g
BFKHEXAM10125	M10 x 1,25	16.6	15.2	13.3	12 H13	9.0	1.3	4.5 g
BFKHEXAM10150	M10 x 1,5	16.6	15.2	13.3	12 H13	9.0	1.3	4.5 g
BFKHEXAM11100	M11 x 1,0	19.8	18.2	15.5	14 H13	10.8	2.0	10.5 g
BFKHEXAM12100	M12 x 1,0	19.8	18.2	15.5	14 H13	10.8	2.0	10.2 g
BFKHEXAM12125	M12 x 1,25	19.8	18.2	15.5	14 H13	10.8	2.0	10.2 g
BFKHEXAM12150	M12 X 1,5	19.8	18.2	15.5	14 H13	10.8	2.0	10.2 g
BFKHEXAM12175	M12 x 1,75	19.8	18.2	15.5	14 H13	10.8	2.0	10.2 g
BFKHEXAM14100	M14 x 1,0	23	21.8	17.8	16 H13	12.0	2.0	11.8 g
BFKHEXAM14125	M14 x 1.25	23	21.8	17.8	16 H13	12.0	2.0	11.8 g
BFKHEXAM14150	M14 x 1,5	23	21.8	17.8	16 H13	12.0	2.0	11.8 g
BFKHEXAM14200	M14 x 2,0	23	21.8	17.8	16 H13	12.0	2.0	11.8 g
BFKHEXAM16150	M16 x 1,5	26	25.3	21.1	19 H13	13.5	2.2	-
BFKHEXAM18150	M18 x 1,5	29	28.3	24.5	19 H13	15.0	2.2	-

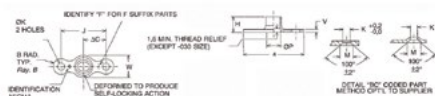

Anchor Nuts

Anchor nut model KM1000
C1050 steel, cadmium finish with anti-friction treatment KayLube Moly. It preserves the mechanical properties up to 235°C. Complies with standard AECMA 2053 (resistance test).

Code	Thread	A	B	C	H	J	K	M	P	V	W
KM1000-030	M3 x 0,5	17,2 mm	3,0 mm	6,0 mm	3,2 mm	12,0 mm	2,5 mm	4,8 mm	-	0,70 mm	6,0 mm
KM1000-040	M4 x 0,7	23,2 mm	3,0 mm	8,5 mm	5,2 mm	17,0 mm	2,5 mm	4,8 mm	4,2 mm	1,00 mm	8,0 mm
KM1000-050	M5 x 0,8	25,2 mm	3,0 mm	9,5 mm	6,2 mm	19,0 mm	2,5 mm	4,8 mm	5,2 mm	1,00 mm	9,0 mm
KM1000-060	M6 x 1,00	29,2 mm	3,0 mm	11,0 mm	7,1 mm	22,0 mm	3,3 mm	6,0 mm	6,2 mm	1,25 mm	10,0 mm
KM1000-080	M8 x 1,25	33,2 mm	3,5 mm	13,0 mm	8,2 mm	26,0 mm	3,3 mm	6,0 mm	8,4 mm	1,65 mm	12,6 mm

WHEEL NUTS AND STUDS



Conical seat

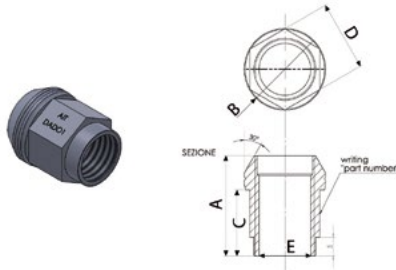

Code	A	B	C	D	E	Application	Material
AIT-DAAL	27 mm	22 mm	19 mm	19 mm	12 x 1.25	Universal	Ergal
AIT-DAAL1	27 mm	22 mm	19 mm	19 mm	12 x 1.5	Universal	Ergal
AIT-DAAL-11	28 mm	28 mm	13 mm	19 mm	12 x 1.5	Universal	Ergal
AIT-DAAL15	27 mm	25 mm	16 mm	3/4"	1/2 UNF	Universal	Ergal
AIT-DAAL-2	34 mm	22 mm	20 mm	19 mm	12 x 1.25	Universal	Ergal
AIT-DAAL-3	34 mm	22 mm	20 mm	19 mm	12 x 1.5	Universal	Ergal
AIT-DAAL6	27 mm	25 mm	16 mm	19 mm	14 x 1.5	Universal	Ergal
AIT-DADO	25 mm	23 mm	14 mm	19 mm	12 x 1,25 mm	Universal	Copper-plated steel
AIT-DADO-1	25 mm	23 mm	14 mm	19 mm	12 x 1,5 mm	Universal	Copper-plated steel
AIT-DADO-10	33 mm	23 mm	23 mm	19 mm	12 x 1,5 mm	Mitsubishi Gr N	Copper-plated steel
AIT-DADO-11	34 mm	23 mm	20 mm	19 mm	12 x 1,25	Universal	Copper-plated steel
AIT-DADO-12	28.5 mm	28 mm	16 mm	19 mm	12 x 1,5	Universal	Copper-plated steel
AIT-DADO-18	25 mm	23 mm	15.5 mm	17 mm	12 x 1,5	Universel	Copper-plated steel
AIT-DADO-2	28 mm	28 mm	13 mm	19 mm	12 x 1,5	Universal	Copper-plated steel
AIT-DADO-4	27 mm	25 mm	16 mm	22 mm	14 x 1,5	Universal	Copper-plated steel
AIT-DADO-6	27 mm	25 mm	16 mm	19 mm	14 x 1,5 mm	Universal	Copper-plated steel
AIT-DADO-9	27 mm	25 mm	15 mm	17 mm	12 x 1,25 mm	Universal	Copper-plated steel



Spherical seat

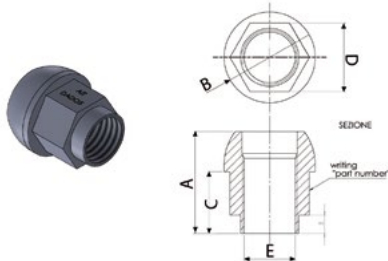

Code	A	B	C	D	E	Application	Material
AIT-DAAL8	31 mm	25 mm	20 mm	19 mm	14 x 1,5	Universal	Ergal
AIT-DADO-19	27 mm	25 mm	17.5 mm	17 mm	12 x 1,5	Universal	Copper-plated steel
AIT-DADO-5	28 mm	25 mm	17 mm	19 mm	14 x 1,5 mm	Universal	Copper-plated steel
AIT-DADO-7	27 mm	25 mm	17 mm	17 mm	12 x 1,25 mm	Universal	Copper-plated steel
AIT-DADO-8	27 mm	25 mm	15 mm	17 mm	12 x 1,25	Universal	Copper-plated steel



Flat seat

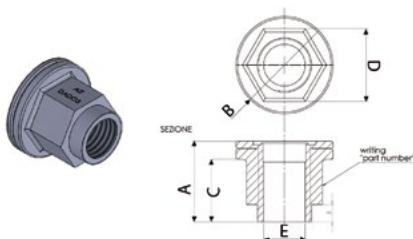

Code	A	B	C	D	E	Application	Material
AIT-DADO-3	29 mm	28 mm	21 mm	19 mm	12 x 1,25 mm	Universal	Copper-plated steel



Double thread wheel studs

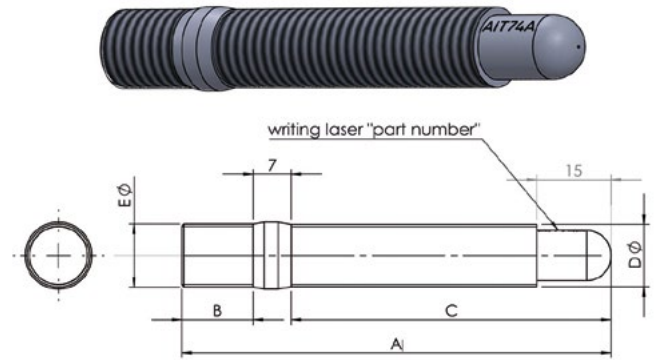

Code	A	B	C	D	E	Application
AIT-102A	102 mm	15 mm	80 mm	12 x 1.25 mm	12 x 1.25 mm	Universal
AIT-102B	102 mm	15 mm	80 mm	12 x 1.25 mm	12 x 1.5 mm	Universal
AIT-102F	102 mm	15 mm	80 mm	12 x 1.5 mm	12 x 1.5 mm	Universal
AIT-102OP	102 mm	15 mm	80 mm	12 x 1.5 mm	12 x 1.5 mm	Universal
AIT-74A	74 mm	15 mm	52 mm	12 x 1.25 mm	12 x 1.25 mm	Universal
AIT-74B	74 mm	15 mm	52 mm	12 x 1.25 mm	12 x 1.5 mm	Universal
AIT-74F	74 mm	15 mm	52 mm	14 x 1.5 mm	14 x 1.5 mm	VW/Audi
AIT-76OP	76 mm	15 mm	54 mm	12 x 1.5 mm	12 x 1.5 mm	Opel
AIT-77M	74 mm	15 mm	52 mm	14 x 1.5 mm	14 x 1.25 mm	BMW-Mini < Jul 06
AIT-86A	86 mm	15 mm	64 mm	12 x 1.25 mm	12 x 1.25 mm	Universal
AIT-86B	86 mm	15 mm	64 mm	12 x 1.25 mm	12 x 1.5 mm	Universal
AIT-86F	86 mm	15 mm	64 mm	14 x 1.5 mm	14 x 1.5 mm	Universal
AIT-86M	86 mm	15 mm	64 mm	14 x 1.5 mm	14 x 1.25 mm	BMW-Mini
AIT-94OP	94 mm	15 mm	72 mm	12 x 1.5 mm	12 x 1.5 mm	Opel



Wheel studs to drive

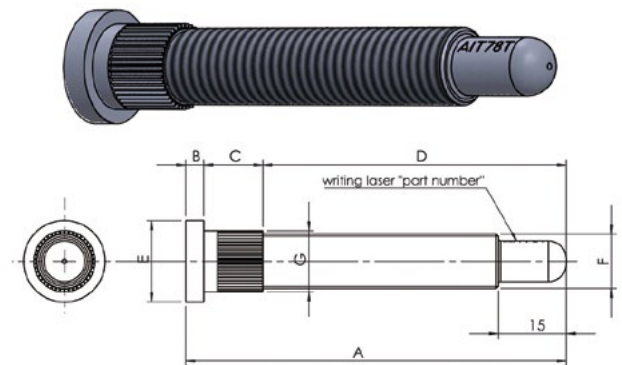

Code	A	B	C	D	E	F	G	Application
AIT-102C	102 mm	4 mm	14 mm	84 mm	17 mm	12 x 1.5 mm	12.8 mm	Ford
AIT-102G	102 mm	5 mm	13 mm	87 mm	20 mm	14 x 1.5 mm	14.8 mm	Porsche
AIT-61F	61 mm	5 mm	15 mm	41 mm	35 mm	14 x 1.5 mm	14.9 mm	Universal
AIT-67M	67 mm	4 mm	8 mm	55 mm	20 mm	12 x 1.5 mm	14.7 mm	Universal
AIT-68N	68 mm	5 mm	7 mm	56 mm	20 mm	12 x 1.25 mm	14.2 mm	Universal
AIT-70N	70 mm	4 mm	10 mm	56 mm	19 mm	12 x 1.25 mm	12.8 mm	Universal
AIT-72S	72 mm	5 mm	10 mm	57 mm	19 mm	12 x 1.25 mm	14.5 mm	Subaru
AIT-73MIT	73 mm	3 mm	7 mm	63 mm	18 mm	12 x 1.5 mm	14.2 mm	Mitsubishi
AIT-74C	74 mm	4 mm	14 mm	56 mm	17 mm	12 x 1.5 mm	12.8 mm	Ford
AIT-74H	74 mm	5 mm	11 mm	58 mm	19 mm	12 x 1.5 mm	12.3 mm	Honda
AIT-74STR	74 mm	9 mm	15 mm	50 mm	24 mm	14 x 1.5 mm	16.9 mm	Universal
AIT-78T	78 mm	5 mm	9 mm	64 mm	18 mm	12 x 1.5 mm	14.3 mm	Toyota
AIT-81G	81 mm	4 mm	11 mm	66 mm	20 mm	14 x 1.5 mm	14.3 mm	Universal
AIT-86C	86 mm	4 mm	14 mm	68 mm	17 mm	12 x 1.5 mm	12.8 mm	Ford



GIEFFE
DISTRIBUTED

NAS Bolts

NAS bolts Series 1303/6603, 160,000PSI resistance. These fine-threaded, dimpled-head hex bolts have a minimum tensile strength of 160,000 psi and a minimum shear strength of 95,000 psi. Thread length is consistent within each diameter (1103/6203 series have a shorter thread), and grips are available in 1/16" increments beginning at 1/16". Used in applications where a premium-quality, high strength bolt is necessary.

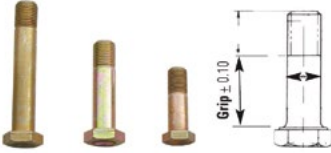

Code	Thread	Grip
1303-01	10-32 UNF	1,59 mm
1303-02	10-32 UNF	3,18 mm
1303-03	10-32 UNF	4,76 mm
1303-04	10-32 UNF	6,35 mm
1303-05	10-32 UNF	7,94 mm
1303-06	10-32 UNF	9,53 mm
1303-07	10-32 UNF	11,11 mm
1303-08	10-32 UNF	12,70 mm
1303-09	10-32 UNF	14,29 mm
1303-10	10-32 UNF	15,88 mm
1303-11	10-32 UNF	17,46 mm
1303-12	10-32 UNF	19,05 mm
1303-13	10-32 UNF	20,64 mm
1303-14	10-32 UNF	22,23 mm
1303-15	10-32 UNF	23,81 mm
1303-16	10-32 UNF	25,40 mm
1303-17	10-32 UNF	26,99 mm
1303-18	10-32 UNF	28,58 mm
1303-19	10-32 UNF	30,16 mm
1303-20	10-32 UNF	31,75 mm
1304-01	1/4" x 28 UNF	1,59 mm
1304-02	1/4" x 28 UNF	3,18 mm
1304-03	1/4" x 28 UNF	4,76 mm
1304-04	1/4" x 28 UNF	6,35 mm
1304-05	1/4" x 28 UNF	7,94 mm
1304-06	1/4" x 28 UNF	9,53 mm
1304-07	1/4" x 28 UNF	11,11 mm
1304-08	1/4" x 28 UNF	12,70 mm
1304-09	1/4" x 28 UNF	14,29 mm
1304-10	1/4" x 28 UNF	15,88 mm
1304-11	1/4" x 28 UNF	17,46 mm
1304-12	1/4" x 28 UNF	19,05 mm
1304-13	1/4" x 28 UNF	20,64 mm
1304-14	1/4" x 28 UNF	22,23 mm
1304-15	1/4" x 28 UNF	23,81 mm
1304-16	1/4" x 28 UNF	25,40 mm
1304-17	1/4" x 28 UNF	26,99 mm
1304-18	1/4" x 28 UNF	28,58 mm
1304-19	1/4" x 28 UNF	30,16 mm
1304-20	1/4" x 28 UNF	31,75 mm
1304-21	1/4" x 28 UNF	33,34 mm
1304-22	1/4" x 28 UNF	34,93 mm
1304-23	1/4" x 28 UNF	36,51 mm
1304-24	1/4" x 28 UNF	38,10 mm
1304-25	1/4" x 28 UNF	39,69 mm
1304-26	1/4" x 28 UNF	41,28 mm
1304-27	1/4" x 28 UNF	42,86 mm
1304-28	1/4" x 28 UNF	44,45 mm
1304-29	1/4" x 28 UNF	46,04 mm
1304-30	1/4" x 28 UNF	47,63 mm
1304-31	1/4" x 28 UNF	49,21 mm
1304-32	1/4" x 28 UNF	50,80 mm

Code	Thread	Grip
1304-34	1/4" x 28 UNF	53,98 mm
1304-60	1/4" x 28 UNF	95,25 mm
1305-01	5/16" x 24 UNF	1,59 mm
1305-02	5/16" x 24 UNF	3,18 mm
1305-03	5/16" x 24 UNF	4,76 mm
1305-04	5/16" x 24 UNF	6,35 mm
1305-05	5/16" x 24 UNF	7,94 mm
1305-06	5/16" x 24 UNF	9,53 mm
1305-07	5/16" x 24 UNF	11,11 mm
1305-08	5/16" x 24 UNF	12,70 mm
1305-09	5/16" x 24 UNF	14,29 mm
1305-10	5/16" x 24 UNF	15,88 mm
1305-11	5/16" x 24 UNF	17,46 mm
1305-12	5/16" x 24 UNF	19,05 mm
1305-13	5/16" x 24 UNF	20,64 mm
1305-14	5/16" x 24 UNF	22,23 mm
1305-15	5/16" x 24 UNF	23,81 mm
1305-16	5/16" x 24 UNF	25,40 mm
1305-17	5/16" x 24 UNF	26,99 mm
1305-18	5/16" x 24 UNF	28,58 mm
1305-19	5/16" x 24 UNF	30,16 mm
1305-20	5/16" x 24 UNF	31,75 mm
1305-21	5/16" x 24 UNF	33,34 mm
1305-22	5/16" x 24 UNF	34,93 mm
1305-23	5/16" x 24 UNF	36,51 mm
1305-24	5/16" x 24 UNF	38,10 mm
1305-25	5/16" x 24 UNF	39,69 mm
1305-26	5/16" x 24 UNF	41,28 mm
1305-27	5/16" x 24 UNF	42,86 mm
1305-28	5/16" x 24 UNF	44,45 mm
1305-29	5/16" x 24 UNF	46,04 mm
1305-30	5/16" x 24 UNF	47,63 mm
1305-31	5/16" x 24 UNF	49,21 mm
1305-32	5/16" x 24 UNF	50,80 mm
1305-34	5/16" x 24 UNF	53,98 mm
1305-38	5/16" x 24 UNF	60,33 mm
1305-40	5/16" x 24 UNF	63,50 mm
1305-42	5/16" x 24 UNF	66,68 mm
1305-44	5/16" x 24 UNF	69,85 mm
1305-56	5/16" x 24 UNF	88,90 mm
1306-01	3/8" x 24 UNF	1,59 mm
1306-02	3/8" x 24 UNF	3,18 mm
1306-03	3/8" x 24 UNF	4,76 mm
1306-04	3/8" x 24 UNF	6,35 mm
1306-05	3/8" x 24 UNF	7,94 mm
1306-06	3/8" x 24 UNF	9,53 mm
1306-07	3/8" x 24 UNF	11,11 mm
1306-08	3/8" x 24 UNF	12,70 mm
1306-09	3/8" x 24 UNF	14,29 mm
1306-10	3/8" x 24 UNF	15,88 mm
1306-11	3/8" x 24 UNF	17,46 mm
1306-12	3/8" x 24 UNF	19,05 mm
1306-13	3/8" x 24 UNF	20,64 mm
1306-14	3/8" x 24 UNF	22,23 mm
1306-15	3/8" x 24 UNF	23,81 mm
1306-16	3/8" x 24 UNF	25,40 mm
1306-17	3/8" x 24 UNF	26,99 mm
1306-18	3/8" x 24 UNF	28,58 mm
1306-19	3/8" x 24 UNF	30,16 mm
1306-20	3/8" x 24 UNF	31,75 mm
1306-21	3/8" x 24 UNF	33,34 mm
1306-22	3/8" x 24 UNF	34,93 mm
1306-23	3/8" x 24 UNF	36,51 mm
1306-24	3/8" x 24 UNF	38,10 mm
1306-25	3/8" x 24 UNF	39,69 mm
1306-26	3/8" x 24 UNF	41,28 mm

Code	Thread	Grip
1306-27	3/8" x 24 UNF	42,86 mm
1306-28	3/8" x 24 UNF	44,45 mm
1306-29	3/8" x 24 UNF	46,04 mm
1306-30	3/8" x 24 UNF	47,63 mm
1306-31	3/8" x 24 UNF	49,21 mm
1306-32	3/8" x 24 UNF	50,80 mm
1306-34	3/8" x 24 UNF	53,98 mm
1306-36	3/8" x 24 UNF	57,15 mm
1306-40	3/8" x 24 UNF	63,50 mm
1306-42	3/8" x 24 UNF	66,68 mm
1306-44	3/8" x 24 UNF	69,85 mm
1306-54	3/8" x 24 UNF	85,73 mm
1306-56	3/8" x 24 UNF	88,90 mm
1307-01	7/16" x 20 UNF	1,59 mm
1307-02	7/16" x 20 UNF	3,18 mm
1307-03	7/16" x 20 UNF	4,76 mm
1307-04	7/16" x 20 UNF	6,35 mm
1307-05	7/16" x 20 UNF	7,94 mm
1307-06	7/16" x 20 UNF	9,53 mm
1307-07	7/16" x 20 UNF	11,11 mm
1307-08	7/16" x 20 UNF	12,70 mm
1307-09	7/16" x 20 UNF	14,29 mm
1307-10	7/16" x 20 UNF	15,88 mm
1307-11	7/16" x 20 UNF	17,46 mm
1307-12	7/16" x 20 UNF	19,05 mm
1307-13	7/16" x 20 UNF	20,64 mm
1307-14	7/16" x 20 UNF	22,23 mm
1307-15	7/16" x 20 UNF	23,81 mm
1307-16	7/16" x 20 UNF	25,40 mm
1307-17	7/16" x 20 UNF	26,99 mm
1307-18	7/16" x 20 UNF	28,58 mm
1307-19	7/16" x 20 UNF	30,16 mm
1307-20	7/16" x 20 UNF	31,75 mm
1307-21	7/16" x 20 UNF	33,34 mm
1307-22	7/16" x 20 UNF	34,93 mm
1307-23	7/16" x 20 UNF	36,51 mm
1307-24	7/16" x 20 UNF	38,10 mm
1307-25	7/16" x 20 UNF	39,69 mm
1307-26	7/16" x 20 UNF	41,28 mm
1307-27	7/16" x 20 UNF	42,86 mm
1307-28	7/16" x 20 UNF	44,45 mm
1307-29	7/16" x 20 UNF	46,04 mm
1307-30	7/16" x 20 UNF	47,63 mm
1307-31	7/16" x 20 UNF	49,21 mm
1307-32	7/16" x 20 UNF	50,80 mm
1307-34	7/16" x 20 UNF	53,98 mm
1307-38	7/16" x 20 UNF	60,33 mm
1307-40	7/16" x 20 UNF	63,50 mm

MAX GEAR 75W/90

Max-Gear is an extremely tough, high-performance GL-5 gear oil designed to provide maximum protection under heavy-duty gearboxes while increasing power through the transmission. Max-Gear outperforms other GL-5 oils as it combines the highest quality synthetic oils with Synslide™, Royal Purple's proprietary synthetic oil film that is so strong and tough it won't be squeezed out of the pressure zone. Max-Gear virtually eliminates gearbox and bearing wear even in extremely difficult "film crushing" conditions caused by very heavy loads, sudden shock loads and low revs. The slippery synthetic molecules not only reduce wear and friction, but significantly increase the fluidity and lubricity of Max-Gear at low temperatures, making it the ideal product for vehicles operating in cold climates. Max-Gear ensures better operation of the gearbox, with less noise, lower temperatures and longer times, without revisions and without corrosion, both for ferrous and non-ferrous metals.



Code	Pack
RP01300	1 l

MAX GEAR 75W/140

Max-Gear is an extremely tough, high-performance GL-5 gear oil designed to provide maximum protection under heavy-duty gearboxes while increasing power through the transmission. Max-Gear outperforms other GL-5 oils as it combines the highest quality synthetic oils with Synslide™, Royal Purple's proprietary synthetic oil film that is so strong and tough it won't be squeezed out of the pressure zone. Max-Gear virtually eliminates gearbox and bearing wear even in extremely difficult "film crushing" conditions caused by very heavy loads, sudden shock loads and low revs. The slippery synthetic molecules not only reduce wear and friction, but significantly increase the fluidity and lubricity of Max-Gear at low temperatures, making it the ideal product for vehicles operating in cold climates. Max-Gear ensures better operation of the gearbox, with less noise, lower temperatures and longer times, without revisions and without corrosion, both for ferrous and non-ferrous metals.



Code	Pack
RP01301	1 l

MAX ATF

Max ATF is a long-lasting, high-performance, multipurpose synthetic fluid for automatic transmissions. Max ATF is recommended for all automatic transmissions that require Ford Mercon or GM Dextron Type III transmission fluids. Max ATF is more stable to oxidation than many other fluids and guarantees greater resistance against failures caused by heat and loss of lubricity. Max ATF is fully compatible with other automatic transmission fluids, but for best results it is recommended that the old fluid be completely drained and refilled with Max ATF.

- Performance benefits
- Reduces operating temperatures.
 - Greater uniformity and precision of the change.
 - Ensures clean and efficient changes.
 - Increases the life of the fluid in operation.



Code	Pack
RP01320	1 l

Synchromax

High performance manual transmission fluid. Synchromax is ideal for 2-stroke motorcycle gearboxes and is formulated with Synerlec, Royal Purple's proprietary synthetic additive that improves gear quality over a wider range of temperatures, reducing gear noise. Synchromax is fully compatible with all friction materials and guarantees high protection against corrosion and oxidation without damaging the light metals commonly used in manual transmission synchronizers.



Code	Pack
RP01512	1 l

MTL

Red Line Oil MTL is a 75W80 GL-4 gear oil, blended with the highest quality group 5 ester base stocks. MTL offers superior gear and synchro protection, balanced friction for easier shifting and reduced drag on moving parts. Ideally suited to synchromesh transmissions, Red Line's MTL offers one of the highest performances of any gear oil on the market making it extremely popular.

- Red Line MTL gear oil features:
- Popular for BMW, Honda and Acura, Ford Focus, late-model Mini Cooper, Dodge & Jeep NV1500, NV3500 and NV5600 truck transmissions
 - Popular replacement for and improvement over GM Synchronesh® (12345349) and Auto-Trak II® (12378508), also Ford Motorcraft® XT-MT-QS
 - Safe for brass synchros, as it lacks the reactive sulfurs found in most GL-5 oils that cause damage
 - Offers quicker shifts, perfect synchronizer coefficient of friction
 - Eliminates notchy shifting, even when cold
 - High performance gear protection and longer synchro life
 - Satisfies the gear oil viscosity requirements of 75W, 80W, and motor oil viscosities of SAE 30, 10W30, and 5W30
 - Recommended for GL-1, GL-3, and GL-4 applications, as well as where most special synchromesh fluids are specified



Code	Pack
50209	946 ml

MT-90

Red Line Oil MT-90 is a 75W90 GL-4 gear oil, blended with the highest quality group 5 ester base stocks. MT-90 offers superior gear and synchro protection, balanced friction for easier shifting and reduced drag on moving parts. Ideally suited to synchromesh transmissions, Red Line's MT-90 offers one of the highest performances of any gear oil on the market making it extremely popular.

- Red Line MT-90 Gear Oil features:
- 75W90 GL-4 gear oil (similar to SAE 5W40/10W40 engine oil viscosity)
 - Popular in Nissan, Mazda, Mitsubishi, VW/Audi, Lotus Elise/Exige, Toyota
 - Offers quicker shifts, perfect synchronizer coefficient of friction
 - Safe for brass synchros, as it lacks the reactive sulfurs found in most GL-5 oils that cause damage
 - High performance gear protection and longer synchro life
 - Eliminates notchy shifting, even when cold
 - Satisfies the gear oil viscosity requirements of 75W, 80W and motor oil viscosities of SAE 40, 10W40, and 15W40
 - Recommended for GL-1, GL-3, and GL-4 applications, as well as where most special synchromesh fluids are specified



Code	Pack
50309	946 ml

GEAR OIL



75W90

Red Line Oil 75W90 is a GL-5 gear oil suited to many transmissions including dog engagement and sequential transmissions, it also works very well in differentials including limited slip. 75W90 is blended with the finest ester base stocks which provide a natural multi-grade, avoiding the need for unstable thickeners and increasing the film strength and temperature stability of the oil. The use of the finest materials available allows Red Line to provide superior protection and unrivalled performance.

Red Line 75W90 Gear Oil features:

- Most popular Red Line gear oil, with thousands of applications for passenger cars, light trucks, and racing vehicles
- Contains additional friction modifiers for suitability with clutch-type limited slip differentials - for most LSDs, no additional friction modifiers are required
- This product is not designed for use in most manual transmissions or tranaxles, since the extreme slipperiness may cause synchronizer mesh issues that lead to shifting problems
- Recommended for API GL-5, GL-6, MT-1, MIL-L-2105E, and SAE J2360



Code	Pack
57909	946 ml



LIGHT SHOCKPROOF

The revolutionary Shockproof range has cemented Red Line as the leading manufacturer of transmission oils. Used at the pinnacle of motorsport including WRC, IndyCar and Sports cars, Shockproof offers performance like no other on the market. Lightweight Shockproof is popular in sequential gearboxes and differentials because of its high levels of protection yet low drag on moving parts, providing minimal power losses through the transmission.

Red Line LightWeight ShockProof™ Gear Oil features:

- Film thickness greater than an SAE 75W140, yet low fluid friction like 80W gear oil or 30W motor oil
- Excellent low-temp flow, improved cold shifting
- For racing differentials under moderate loads
- Popular in racing transmissions like Hewland and other Road Racing dog-ring boxes, Bert and Brinn for Stock Cars, G-Force, and Liberty clutchless for Drag Racing



Code	Pack
58409	946 ml



HEAVY SHOCKPROOF

The revolutionary Shockproof range has cemented Red Line as the leading manufacturer of transmission oils. Used at the pinnacle of motorsport including WRC, IndyCar and Sports cars, Shockproof offers performance like no other on the market. Heavyweight Shockproof is popular in sequential gearboxes and differentials because of its extreme levels of protection, works very well in excessive temperatures and is recommended by Sadev.

Red Line Heavy Shockproof™ Gear Oil features

- Film thickness greater than an SAE 75W250, yet low fluid friction like 75W90
- For heavily-loaded racing differentials and transmissions, problem gearboxes
- Many performance racing applications like Sprint/Midget/Dirt Late Model Differentials, Detroit Lockers and spools, NHRA Top Fuel and Funny Car rear ends
- Not recommended for most synchro applications due to the product's extreme slipperiness



Code	Pack
58209	946 ml

MOTOR OIL



NEO 75W90RHD

NEO 75w90RHD synthetic gear oil is designed to take 80% more load carrying capabilities than its competitors. NEO 75w90RHD is compounded with the most recently developed additive system to provide the ultimate in gear protection, from an E.P. wear, corrosive wear, and shock load wear standpoint. A friction modifier is also employed to reduce sliding friction resulting in lower energy requirements, thus less drag, lower fuel consumption, and more horsepower. NEO synthetic gear oils offer both cold temperature advantages (Pour Point is -45)



Code	Pack
NEO-75W-90RHD	3,785 l (1 US gallon)



XPR 5W-30

Royal Purple's XPR 5W-30 Extreme Performance Racing is specifically formulated for the demands of multi-platform racing environments. XPR achieved popularity in a variety of motorsports including NASCAR, NHRA, World of Outlaws, and Bonneville Salt Flats. XPR combines the highest quality of synthetic base oil with Royal Purple's proprietary Synerlec additive technology. Combined with additional performance enhancers to create a lubricant that maximizes horsepower and torque, while providing the highest level of protection against heat and wear. XPR provides more protection than leading synthetics and conventional lubricants including those combined with aftermarket additives. With Royal Purple professional engine builders and race teams cite increased horsepower and longer engine life, that gains its performance advantages from Royal Purple's proprietary Synerlec additive technology.



Code	Pack
RP01021	946 ml



XPR 10W-40

Royal Purple's XPR 10W-40 Extreme Performance Racing is specifically formulated for the demands of multi-platform racing environments. XPR achieved popularity in a variety of motorsports including NASCAR, NHRA, World of Outlaws, and Bonneville Salt Flats. XPR combines the highest quality of synthetic base oil with Royal Purple's proprietary Synerlec additive technology. Combined with additional performance enhancers to create a lubricant that maximizes horsepower and torque, while providing the highest level of protection against heat and wear. XPR provides more protection than leading synthetics and conventional lubricants including those combined with aftermarket additives. With Royal Purple professional engine builders and race teams cite increased horsepower and longer engine life, that gains its performance advantages from Royal Purple's proprietary Synerlec additive technology.



Code	Pack
RP01041	946 ml

RED LINE
CV joint grease

Red Line CV-2 Grease is designed to withstand the extreme temperatures and pressures which occur in high-performance wheel bearings and CV-joints. The excellent high-temperature stability, extreme pressure protection, and water resistance enables it to out-perform even the best conventional or synthetic greases. Red Line CV-2 Grease can be used in a wide range of applications at temperatures ranging between -100°F to 500°F and provides good oxidation and corrosion resistance, low evaporation and oil separation, and has a minimum effect on rubber seals. 397 g



Code	Description
CV2	Red Line CV-2 High temperature Grease

NEO SYNTHETICS
CV joint grease

NEO CV 500 Grease is a complex blend of mineral oils, synthetic esters and lubricating solids. NEO CV500 should be used when temperature extremes are not a problem. (See special note.) Their designed use is for severe sliding contact such as extremely heavily loaded ways and guides, very slow, large diameter ball and roller bearings, bushings, linear and oscillating mechanisms and open gears. Articulated, CV and Universal Joints subject to the hardest shock loading, angularity and radial forces such as found on ALL-TERRAIN VEHICLES. Can be used on sensitive metallurgy including copper, silver, tin and aluminum and their alloys. Exceptionally resistant to water wash conditions including emulsions. Special compounding and lubricating solids provide superior anti-seize characteristics and exceptional acid resistance. Constant Velocity & Articulated Joint Lubricant Anti-seize Lubricating Paste to 1200°F 453g



Code	Description
NEO-CV500	High temperature CV joint grease NEO CV500 - 453 g

MOTORSPORT
CV joint grease

The CV Joint grease has been specially formulated for CV Joints and in particular for motorsport use. The grease has an ultra high load carrying capacity, ensuring even in the most competitive environments the joints remain lubricated. The grease is suitable for most types of CV or 'Lobro' type joints, including fixed or plunging types, so is equally useful for replenishment or replacement greasing rather than solely lubricating for new joint installations. One 320g tube generally suits a set of four joints (80g each)



Code	Description
MS9U025	CV Joint Grease - 300 g

NEO SYNTHETICS
CV joint grease

High Performance Calcium Complex CV Joint Grease NEO HPCC1 is a specialty grease used for linear and oscillating mechanisms and couplings, such as constant velocity couplings (CV joints) and sealed bearings. It will take heavy shock loads, frequent axial movements, large speed variations, and frequent reversing. It is made with a higher molecular weight synthetic base stock and will withstand extreme temperatures. It has a very strong resistance to water washout in rain or even salt water. NEO HPCC1 Grease is designed for low oil separation under centrifuging. It is classified as an NLGI 1 which makes it relatively soft and adaptable. 360g



Code	Description
NEO-HPCC1-12.5OZ	High Performance Calcium Complex CV Joint Grease NEO HPCC1 - 360 g

NEO SYNTHETICS
CV joint grease

High Temperature Wheel Bearing Grease NEO HP800 Heavy Duty EP grease for plain and rolling element bearings, and sliding mechanisms operating generally difficult conditions. Exceptionally resistant to water wash out including emulsions, NEO HP800 was designed specifically for precision rolling element bearings in high performance racing cars. This grease is slightly thinner in consistency and has a higher viscosity synthetic fluid incorporated in its design as compared to greases normally used for passenger vehicles and is designed to lubricate to 425°C (800°F) 453g



Code	Description
HP800	High Temperature Wheel Bearing Grease NEO HP800 - 453 g

IMMAGINE NON DISPONIBILE
Red Rubber Grease

Special grease compatible with rubber, rubber components for use in plumbing brake and clutch where you want to avoid hardening or swelling. 500g.



Code	Description
5196TB	Red Rubber Grease - 500 gr.

MOLYSLIP
Anti-Seize Compound

Molyslip Copaslip is an anti-seize compound consisting of micro-sized particles of copper in a non-melt bentone grease with highly effective oxidation and corrosion inhibitors. Copaslip ensures rapid and easy assembly of threaded parts, reduces torque, prevents seizing and galling, gives quick and easy breakout of threads, gaskets and packings (even after long exposure to high temperature, corrosive conditions or extreme surface pressures), and reduces wear in areas of high friction. Can be used in any temperature from sub-zero to 1100°C (2000°F). Solidifies at -18°C (0°F) and has been formulated and produced to provide: Protection against seizure - even in extreme service conditions Ease and economy of labour when assembling and dismantling equipment Protection against rust, oxidation and other corrosion, especially with dissimilar metals



Code	Pack
COPA100	100 g - Squeeze tube
COPA500	500 g - Can

HYLOMAR
Gasket & Jointing Compound

Hylomar Universal Blue is the World's leading non setting sealant and gasket compound. For many years it has been used by automotive original equipment manufacturers and world class racing teams alike. Hylomar Blue can withstand high temperatures and intense vibration and is resistant to fuels, oils, water, coolants and refrigerants. Hylomar Universal Blue can be used for sealing joint faces or threads and is effective on metal or plastic and because it is a non setting compound it allows joints to be separated easier and offers an unlimited assembly time.



Code	Description
HYLOMAR	Sealant Hylomar Universal Blue - 100 g squeeze tube

OTOSOL
Metal polish

The polishing compound for metals Autosol cleans and protects chrome, aluminum, brass, copper and steel, removes traces of rust and corrosion.



Code	Description
SOLVOL	Metal polish Autosol - 75 ml



Coolers Additives

This EVANS waterless coolant is the result of decades of research and development. Engineers have specifically created CLASSIC COOL 180° for Historic Vehicles with engines made of cast iron blocks and copper, steel and aluminum components. This coolant keeps engines at the right temperature in the harshest conditions. (freezing point at -40°C) In addition to improving your cooling system, EVANS coolant helps improve the life of your engine. This protection will be active all the life of the engine without being replaced!

- No overheating: The boiling point of EVANS coolant is above 180°C.
- Without water, EVANS coolant helps prevent and eliminate corrosion.
- Without water, EVANS coolant reduces the pressure in the cooling system.
- By preventing the build-up of hard scale, EVANS coolant prevents inefficient heat transfer.
- More Power: Premature detonation associated with overheating is eliminated with this waterless coolant.



Code	Pack	Type
EVCC2	2 L	Classic Coolant
EVCC5	5 L	Classic Coolant



Coolers Additives



Code	Pack	Type
80234	358 ml	Coolant



Coolers Additives

Concentrated coolant additive for radiators. Reduces the temperature of the coolant and the engine. It does not contain glycol. Protects the aluminum cooling system. Lubricates the water pump seals. Guarantees corrosion resistance (conforms to ASTM D-2570). Dilution from 3% to 5%. (NB: Do not use with distilled water) Works with petrol and diesel engines



Code	Pack	Type
PICE360	360 ml	Coolant



Coolers Additives

Power Cool 180° waterless coolant virtually eliminates overheating in gasoline and diesel engines. It allows the motors to withstand higher temperatures, without boiling and allows the cooling system to run at very low or almost zero pressure. Thanks to the absence of water in the system, engines with NPG are free from electrolysis and work perfectly regardless of the type of driving and environmental conditions. Cooling systems using EVANS technology use non-water based, high boiling point refrigerant (over 180 ° C), keeping the refrigerant temperature considerably below boiling point.



Code	Pack	Type
EVPC5	5 L	Power Coolant



Coolers Additives

Evans Prep Fluid is a waterless cooling system flush engineered specifically to purge the cooling system of water-based antifreeze after draining and before installing new waterless coolant. Prep Fluid should be used when block drains are unavailable or cannot be removed. It is not a substitute for thoroughly draining the cooling system and related components. Prep Fluid is NOT intended to be a stand-alone operating coolant, but as a flush only. For use with all engines being converted to any Evans waterless coolant, after draining 50-50 coolant from the cooling system. Evans Prep Fluid is ready to use—no water required.

- Hygroscopically absorbs water
- Ensures all residual water is removed from the system
- Ensures that Evans coolants will meet the water content limits and provide peak performance
- Protects cooling system metals during flush



Code	Pack	Type
EVPF2	2 L	Cleaner
EVPF5	5 L	Cleaner



Liquid penetrants

A range of essential products for detecting even the smallest cracks in metals. A range consisting of a solvent for cleaning the metal, a developer to homogenise the contrasting surface colour and the detector that is easily displayed on the contrasting surface. For features, see the individual product sheets.



Codice	Use	Colour	Pack
V-T009A	Solvent	Clear	Spray 400ml
V-T009B	Penetrant-detector	Red	Spray 400ml
V-T009C	Developer	White	Spray 400ml



Coolers Additives

Removes rust, oil, grease, metal and limescale from the engine cooling circuit. Compatible with all rubbers, metals, aluminum and plastic parts of the cooling circuit. It does not contain acids and does not need neutralizers. Safe on all engines and radiators also in aluminum.



Code	Pack	Type
RX4009	250 ml	Cleaner



Fuel additives



Code	Description
94600253	Diesel additive F51 - 1 liter



Friction eliminators



Code	Pack
RX101	250 ml



Brakes cleaner



Code	Description
08901087	Brake cleaner Wurth



Fuel additives

Royal Purple's new Max-Boost is a high performance octane booster and fuel treatment for racing applications that increases gasoline octane, reduces emissions, and enhances engine performance while stabilizing fuel. Formulated with MMT, Max-Boost delivers the best octane enhancement to help eliminate engine-damaging detonation, pre-ignition, and pinging or knocking from low-octane gasoline. Max-Boost is the best fuel system stabilizer for anyone looking to significantly boost engine performance and efficiency. Max-Boost fuel system stabilizer is formulated for racing engines equipped with carburetors, port fuel injection and direct injection, as well as turbocharged, supercharged and nitrous-injected engines. Safe for use in leaded and unleaded gasoline, and alternate fuels like gasohol, reformulated gasoline, and all ethanol blends. Our premium fuel system stabilizer is also safe for oxygen sensors and catalytic converters. Ready to outperform



Code	Description
RP11757	MAX-BOOST™ Octane booster & fuel system stabilizer 473 ml



Fuel additives

Product for immediate cleaning of fuel tanks contaminated with algae and sludge or as an essential part of any preventive maintenance program.

- Effective with diesel, ultra low sulfur diesel (ULSD), biodiesel and gasoline fuels.
- Cleans fuel tanks contaminated with algae and sludge.
- Disperses water and protects against conditions that favor microbial growth.
- Prevents premature clogging of fuel filters caused by algae and sludge.
- Contains Petrofresh™, which stabilizes the fuel in the event of a long stay in the tank.
- Prevents the formation of sludge.
- Protects the components of the fuel system against organic acids created by algae and sludge prevents corrosion of the tank.
- Avoid the use of additives, biocides and agents for water dispersion



Code	Description
PS09225	Additive Clear Diesel - 0,946 lt



Multipurpose lubricants WD40

WD40 is 5 Products in one... at price for one.

- WATER RESISTANT: WD-40 removes water and forms a protective barrier moisture resistant.
- CORROSION: WD-40 protects metal surfaces from corrosion, even in critical conditions.
- LUBRICANT: WD-40 lubricates everything properly and without silicone.
- UNLOCKING: WD-40 unlocks the seized parts and rusty mechanisms, blocked or frozen.
- CLEANER WD-40 easily removes grease, tar, glue ...



Code	Pack
WD40-250	250 ml - Spray
WD40-400	400 ml - Spray
WD40-5LT	5L - Container



Glass fiber mat

Glass fiber needled mat stitched KT600
 Thermal stability: 500° C (fiber) - 200° C (Thread)
 Melting point: 835° C
 Thickness: 7 mm (+/- 1)
 Width: 100 cm
 Weight: 1600 g/mq (+/- 12%)
 Density: 250 Kg/mc
 Price per meter.



Code	Description
T.020.096.0000	Glass fiber needled mat stitched



Exhaust heat protection

Fabrics for the exhausts lining, reduces the temperature by up to 70%!
 Pack 50mm x 15m.



Code	Description
10002-15	Exhaust heat protection - 50 mm x 15 m



Heat Resisting Cloth

Fiberglass weave with aluminum film thermo reflective.
 Sold per square meter



Code	Sticky	Thickness/weight	Note
ALFOL41	No	0,25 mm	500° C
ALFOL601	No	1,0 mm	500° C
EKC622A	Yes	700 gr/m²	500° C - adhesive dissolves at 120° C



Heat Protection Foil

Heat protection foil suitable for the protection of the body close to heat sources, exhausts, catalyts, etc.



Code	Description
LAM	Heat Protection Foil - 200 x 60 cm



Gold film

The Gold Reflective Film is an aerospace material capable of reflecting 78% of all radiant heat with continuous operating temperatures of 675° F.
 The material is metalized poyamide polymer laminated glass cloth with a high temperature pressure sensitive adhesive. The film is lightweight at only 5oz per square yard, and is easy to apply and remove.
 60 x 100 cm sheet



Code	Description
GOLDFILM	Gold reflective film - 60 x 100 cm sheet