

EN17

COOL
ING
SYSTEMS

Setrab
ProLine STD Half width

Pro Line STD Half Width, 210 mm.

Technical Specifications

Working Pressure: 0-10 bar(g) dynamic
Pressure Pulsation Endurance: 200k pulsations, 0-10 bar(g), 2 Hz, 60°C oil temp
Max Pressure: 12 bar(g)
Burst Pressure: 37 bar(g)
Pressure Test: 10 bar(g)
Leak Test: 4 bar(g)
Working Temperature: -40°C to 150°C
Corrosion Endurance: 20 days according to SWAAT G85-94 A3
Inner Cleanliness: ISO 4406 16/14
General Dimensional Tolerances: ISO 2768-v
Material: Aluminium alloys
Max Connection Tightening Torque: 40 Nm

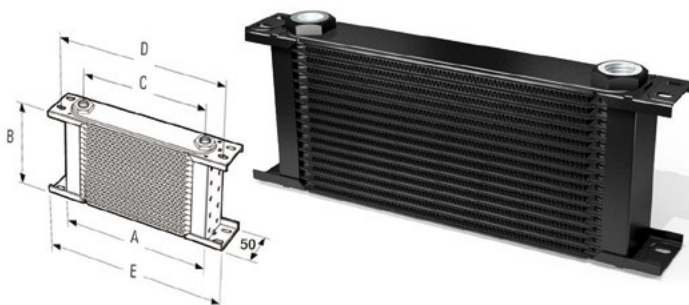

Code	Body width (A) mm	Height (B) mm	Connections distance (C) mm	Hole centers (D) mm	Total width (E) mm	Rows
STD HALF WIDTH						
50-107-7612	163	52,3 ±2	122	190	210	07
50-110-7612	163	76,0 ±2,5	122	190	210	10
50-113-7612	163	99,2 ±2,5	122	190	210	13
50-116-7612	163	121,9 ±3	122	190	210	16
50-119-7612	163	145,6 ±3	122	190	210	19
50-125-7612	163	193,0 ±3	122	190	210	25
50-150-7612	163	388,5 ±3	122	190	210	50
STD FULL WIDTH						
50-607-7612	283	52,3 ±2	242	310	330	07
50-610-7612	283	76,0 ±2,5	242	310	330	10
50-613-7612	283	99,2 ±2,5	242	310	330	13
50-616-7612	283	121,9 ±3	242	310	330	16
50-619-7612	283	145,6 ±3	242	310	330	19
50-625-7612	283	193,0 ±3	242	310	330	25
50-634-7612	283	263,6 ±3	242	310	330	34
50-640-7612	283	310,0 ±3	242	310	330	40
50-644-7612	283	342,0 ±3	242	310	330	44
50-650-7612	283	389,0 ±3	242	310	330	50
STD EXTRA WIDTH						
50-910-7612	358	76,0 ±2,5	317	385	405	10
50-913-7612	358	99,2 ±2,5	317	385	405	13
50-915-7612	358	115,0 ±2,5	317	385	405	15
50-919-7612	358	145,6 ±3	317	385	405	19
50-925-7612	358	193,0 ±3	317	385	405	25

Setrab
ProLine SLM

For cooling transmission, rear axle, motorcycle, developed for applications with restricted packaging space. A high performance Slimline cooler, redesigned and strengthened for the automotive racing market.

Technical Specifications

Working Pressure:
 6-row: 0-8 bar(g) dynamic
 10-row: 0-8 bar(g) dynamic
 14-row: 0-6 bar(g) dynamic
Pressure Pulsation Endurance
 6-row: 200k pulsations, 0-8 bar(g), 2 Hz, 60°C oil temp
 10-row: 200k pulsations, 0-8 bar(g), 2 Hz, 60°C oil temp
 14-row: 50k pulsations, 0-8 bar(g), 2 Hz, 60°C oil temp
Max Pressure: 10 bar(g)
Burst Pressure: 25 bar(g)
Pressure Test:
 6-row: 8 bar(g)
 10-row: 8 bar(g)
 14-row: 6 bar(g)
Leak Test: 4 bar(g)
Working Temperature: -40°C to 150°C
Corrosion Endurance: 20 days according to SWAAT G85-94 A3
Inner Cleanliness: ISO 4406 16/14
General Dimensional Tolerances: ISO 2768-v
Material: Aluminium alloys
Max Connection Tightening Torque: 40 Nm

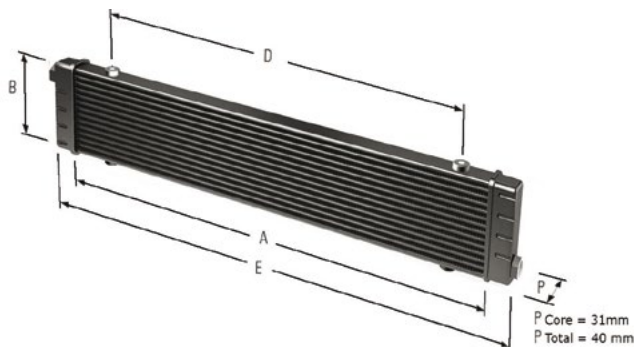

Code	Body width (A) mm	Height (B) mm	Connections distance (C) mm	Hole centers (D) mm	Total width (E) mm	Rows
53-10740	141	51 (core) - 63 (tot)	-	90 (M6)	204	06
53-10741	141	87 (core) - 99 (tot)	-	90 (M6)	211	10
53-10742	141	122 (core) - 136 (tot)	-	90 (M6)	211	14
53-10743	250	51 (core) - 63 (tot)	-	200 (M6)	313	06
53-10744	250	87 (core) - 101 (tot)	-	200 (M6)	320	10
53-10745	250	122 (core) - 136 (tot)	-	200 (M6)	320	14
53-10746	420	51 (core) - 65 (tot)	-	320 (M6)	483	06
53-10747	420	87 (core) - 101 (tot)	-	320 (M6)	490	10
53-10748	420	122 (core) - 136 (tot)	-	320 (M6)	490	14
53-10749	592	51 (core) - 65 (tot)	-	492 (M6)	655	06
53-10750	592	87 (core) - 101 (tot)	-	492 (M6)	662	10
53-10751	592	122 (core) - 136 (tot)	-	492 (M6)	662	14

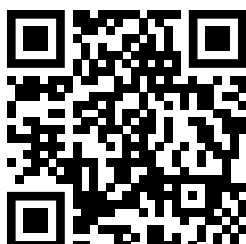

OIL COOLER CONNECTIONS

Setrab
Oil Cooler Connections

Thanks to the wide availability of optional adapters, supplied complete with o-ring, fillets output of the coolers can be varied at will.
To use AN JIC/UNF fittings you will need to purchase x2 adaptors and x2 O-rings, per cooler.



Code	Type	Thread
22-09475-01	Adaptor	JIC 9/16 x 18
22-09476-01	Adaptor	JIC 3/4 x 16
22-09477-01	Adaptor	JIC 7/8 x 14
22-09478-01	Adaptor	JIC 1 1/16 x 12
22-09479-01	Adaptor	JIC 1 5/16 x 12
22-M22BJAN08-90	Swivel banjo	JIC 3/4 x 16
22-M22BJAN10-90	Swivel banjo	JIC 7/8 x 14
22-M22BJAN12-90	Swivel banjo	JIC 1 1/16 x 12
25-233	Oil seal	-

MOCAL
Sandwich Plates

Sandwich Plates are sold with 2 female threads M22x1.5. They are available in 2 versions: with central connection for filter 3/4" UNF (AN8) or M20 x 1,50.



Code	Connection	Thread	Note
OTSP1F-M22	M20 x 1,5	M22 x 1,5	With thermostat
OTSP1-M22	3/4 UNF (AN8)	M22 x 1,5	With thermostat
SP100	3/4 UNF (AN8)	M22 x 1,5	Billet
SP100F	M20 x 1,5	M22 x 1,5	Billet
SP1F-M22	M20 x 1,5	M22 x 1,5	Standard
SP1-M22	3/4 UNF (AN8)	M22 x 1,5	Standard

OIL PUMPS

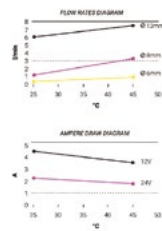
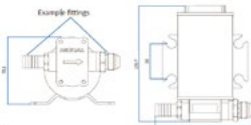

MOCAL
Oil Pumps

Electric Fluid Circulation Pumps can also be used for other applications like circulating coolant for water radiators, intercoolers and driver cool suits. Motors utilize ball bearing drive throughout and integral cooling fan for long life. Pump is a positive displacement design which is self priming and can be located up to 8 feet above fluid/feed.
Pump body in nylon. Inlet and outlet 3/8NPTF (rotated by 90 ° increments).
Connections: 3/8 NPTF thread.
Max temperature: 130°C 150°C intermittent
Max pressure: 3.5 bar (50 PSI)
Flow rate: 7.5 L/min - Oil at 130°C
Power supply: 12V DC - 8A

Codice	Weight	Voltage	Max temperature	Operating Temperature	Max current	Flow rate	Max pressure
EOP2	1,4 Kg	12 V	150 °C	130 °C	7,5 A	0.3 - 7.5 l/min	30 PSI / 2 Bar

Updates on the website



Can't find some news?
Look for them on www.giefferacing.com.
Subscribe to the newsletter to be informed about news and not miss our offers!



MOCAL
Oil pump repairing kits

Code	Fitting pump
OPP6B	Mocal TCP1

OIL/WATER HEAT EXCHANGERS



General Information
 The Laminova heat exchangers are available in different length and diameters and with or without restrictor for the coolant flow. The cooling performance increases with the length and diameter of the cooler.
Specific information
 Core diameter 43 mm. Available in 92, 182 and 332 mm length.
Guideline:
 Coolant flowrates > 80 l/min: No restrictor is normally needed.
 Coolant flowrates < 80 l/min: A plug or a restrictor can be used.



Code	Body type	Oil connection	Water connection Ø
C43-18076-M16	180	-06	16 mm
C43-18076-M18	180	-06	18 mm
C43-18076-M28	180	-06	28 mm
C43-18076-M32	180	-06	32 mm
C43-18076-M35	180	-06	35 mm
C43-18076-M38	180	-06	38 mm
C43-18076-M45	180	-06	45 mm
C43-18078-M16	180	-08	16 mm
C43-18078-M18	180	-08	18 mm
C43-18078-M28	180	-08	28 mm
C43-18078-M32	180	-08	32 mm
C43-18078-M35	180	-08	35 mm
C43-18078-M38	180	-08	38 mm
C43-18078-M45	180	-08	45 mm
C43-180710-M16	180	-10	16 mm
C43-180710-M18	180	-10	18 mm
C43-180710-M28	180	-10	28 mm
C43-180710-M32	180	-10	32 mm
C43-180710-M38	180	-10	38 mm
C43-180710-M45	180	-10	45 mm
C43-180712-M18	180	-12	18 mm
C43-180712-M28	180	-12	28 mm
C43-180712-M32	180	-12	32 mm
C43-180712-M35	180	-12	35 mm
C43-180712-M38	180	-12	38 mm
C43-180712-M45	180	-12	45 mm
C43-180716-M16	180	-16	16 mm
C43-180716-M18	180	-16	18 mm
C43-180716-M28	180	-16	28 mm
C43-180716-M32	180	-16	32 mm
C43-180716-M38	180	-16	38 mm
C43-180716-M45	180	-16	45 mm
C43-33076-M16	330	-06	16 mm
C43-33076-M18	330	-06	18 mm
C43-33076-M28	330	-06	28 mm
C43-33076-M32	330	-06	32 mm
C43-33076-M38	330	-06	38 mm
C43-33076-M45	330	-06	45 mm
C43-33078-M32	330	-08	32 mm
C43-33078-M38	330	-08	38 mm
C43-330710-M16	330	-10	16 mm
C43-330710-M18	330	-10	18 mm
C43-330710-M32	330	-10	32 mm
C43-330710-M35	330	-10	35 mm
C43-330710-M38	330	-10	38 mm
C43-330710-M45	330	-10	45 mm
C43-330712-M18	330	-12	18 mm

Code	Body type	Oil connection	Water connection Ø
C43-330712-M28	330	-12	28 mm
C43-330712-M32	330	-12	32 mm
C43-330712-M35	330	-12	35 mm
C43-330712-M38	330	-12	38 mm
C43-330712-M45	330	-12	45 mm
C43-330716-M32	330	-16	32 mm
C43-330716-M35	330	-16	35 mm
C43-330716-M38	330	-16	38 mm
C43-330716-M45	330	-16	45 mm
C43-9076-M16	90	-06	16 mm
C43-9076-M18	90	-06	18 mm
C43-9076-M28	90	-06	28 mm
C43-9076-M32	90	-06	32 mm
C43-9076-M35	90	-06	35 mm
C43-9076-M38	90	-06	38 mm
C43-9076-M45	90	-06	45 mm
C43-9078-M16	90	-08	18 mm
C43-9078-M18	90	-08	18 mm
C43-9078-M28	90	-08	28 mm
C43-9078-M32	90	-08	32 mm
C43-9078-M38	90	-08	38 mm
C43-90710-M18	90	-10	18 mm
C43-90710-M28	90	-10	28 mm
C43-90710-M32	90	-10	32 mm
C43-90710-M38	90	-10	38 mm
C43-90712-M16	90	-12	16 mm
C43-90712-M18	90	-12	18 mm
C43-90712-M28	90	-12	28 mm
C43-90712-M32	90	-12	32 mm
C43-90712-M38	90	-12	38 mm
C43-90716-M32	90	-16	32 mm

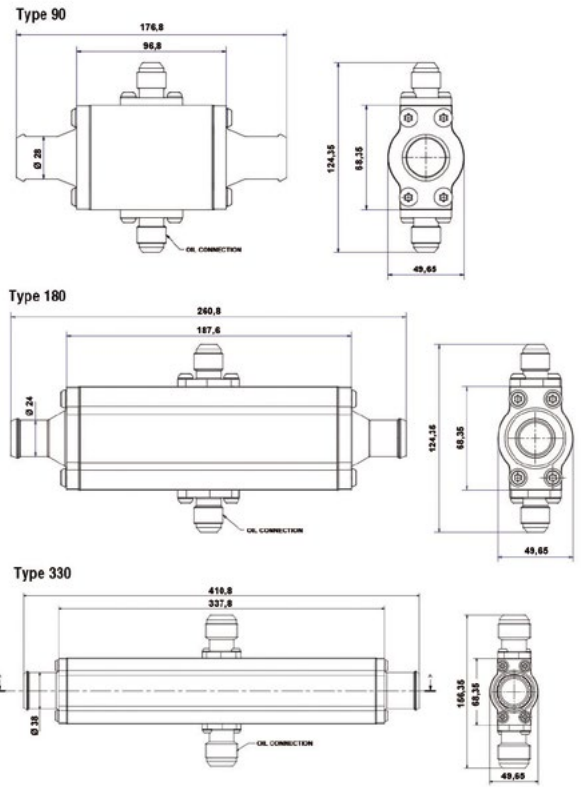

Code	Description
LSK1	Laminova C43 standard service kit

Code	Description
7711156203	Laminova service kit for Renault

WATER PUMPS



Model with a larger capacity (115 liters per minute) for vehicles with high-performance and 4WD engines that require greater cooling.
 Kit contents:
 - EWP115 pump (1 pc)
 - 8515 Wiring harness (1 pc)
 - 8510 Sleeve 3mm rubber adaptors (2 pcs)
 - 8512 Hose clamps (2 pcs)
 - 8525 Assorted hardware bag (1 pc)
 - 0533 Relay (1 pc)
 not included: 8505 - 90° hose adaptor (optional)

Code	Max Flow rate	Material	Voltage	Max current	Operating Temperature	Weight	Max pressure	Fits hose sizes	Motor life	EWP Fan Digital controller
EWP115	115 l/min at 13V DC	Nylon66 30% Glass filled	3V - 15V DC	10A	-40 °C / +130 °C	980 g	500 kPa (72,5 PSI)	32 - 51 mm	3000 h continuous at 80°C 12V DC 7000 h with EWP Fan digital controller	No



Aluminum model with a capacity of 115 liters per minute, for vehicles with high-performance and 4WD engines that require greater cooling.
 Kit contents:
 - EWP115 alloy pump (1 pc)
 - 8515 Wiring harness (1 pc)
 - 8510 Sleeve 3mm rubber adaptors (2 pcs)
 - 8512 Hose clamps (2 pcs)
 - 8525 Assorted hardware bag (1 pc)
 - 0533 Relay (1 pc)
 not included: 8505 - 90° hose adaptor (optional)

Code	Max Flow rate	Material	Voltage	Max current	Operating Temperature	Weight	Max pressure	Fits hose sizes	Motor life	EWP Fan Digital controller
EWP8040	115 l/min at 13V DC	Aluminium	3V - 15V DC	10A	-40 °C / +130 °C	980 g	500 kPa (72,5 PSI)	38 - 51 mm	3000 h continuous at 80°C 12V DC 7000 h with EWP Fan digital controller	No



Model with capacity of 115 liters per minute, with integrated Digital Controller; for vehicles with high-performance and 4WD engines that require greater cooling.
 Kit contents:
 - EWP115 pump (1 pc)
 - 8515 Wiring harness (1 pc)
 - 8510 Sleeve 3mm rubber adaptors (2 pcs)
 - 8512 Hose clamps (2 pcs)
 - 8525 Assorted hardware bag (1 pc)
 - 0533 Relay (1 pc)
 - 8020 Controller combo kit (1 pc)
 not included: 8505 - 90° hose adaptor (optional)

Code	Max Flow rate	Material	Voltage	Max current	Operating Temperature	Weight	Max pressure	Fits hose sizes	Motor life	EWP Fan Digital controller
EWP8030	115 l/min at 13V DC	Nylon66 30% Glass filled	3V - 15V DC	10A	-40 °C / +130 °C	980 g	500 kPa (72,5 PSI)	38 - 51 mm	3000 h continuous at 80°C 12V DC 7000 h with EWP Fan digital controller	Yes (EWP8060)



Standard model (80 liters per minute) for cars with capacity up to 5 litres
 Kit contents:
 - EWP80 pump (1 pc)
 - 8307 EWP Straight Adaptor 35mm (1 pc)
 - 8309 EWP L-Adaptors 35mm (1 pc)
 - 8509 EWP Adaptor O-Ring (2 pcs)
 - 8515 EWP Basic Pump Loom (1 pc)
 - 8510 EWP Sleeve 3mm (2 pcs)
 - 8512 Hose Clamp (2 pcs)
 - 8908 EWP80 Hardware Bag (1 pc)
 - 0533 Relay (1 pc)

Code	Max Flow rate	Material	Voltage	Max current	Operating Temperature	Weight	Max pressure	Fits hose sizes	Motor life	EWP Fan Digital controller
EWP80	80 l/min at 13,5V DC	Nylon66 30% Glass filled	3V - 15V DC	7,5A	-20 °C / +130 °C	900 g	350 kPa (50 PSI)	32 - 51 mm	3000 h continuous at 80°C 12V DC 6000 h with EWP Fan digital controller	No

WATER PUMPS



Model with capacity of 80 liters per minute, with integrated Digital Controller; for cars with capacity up to 5 litres

- EWP80 pump (1 pc)
- 8307 EWP Straight Adaptor 35mm (1 pc)
- 8309 EWP L-Adaptors 35mm (1 pc)
- 8509 EWP Adaptor O-Ring (2 pcs)
- 8515 EWP Basic Pump Loom (1 pc)
- 8510 EWP Sleeve 3mm (2 pcs)
- 8512 Hose Clamp (2 pcs)
- 8908 EWP80 Hardware Bag (1 pc)
- 0533 Relay (1 pc)
- 8020 Controller combo kit (1 pc)

Code	Max Flow rate	Material	Voltage	Max current	Operating Temperature	Weight	Max pressure	Fits hose sizes	Motor life	EWP Fan Digital controller
EWP8007	80 l/min at 13,5V DC	Nylon66 30% Glass filled	3V - 15V DC	7,5A	-20 °C / +130 °C	900 g	350 kPa (50 PSI)	32 - 51 mm	3000 h continuous at 80°C 12V DC 6000 h with EWP Fan digital controller	Yes (EWP8060)



The world's first universal-fit, automotive Electric Water Pump goes one better with the EWP@150. Suitable for all makes and models – will excel on large six-cylinder engines, V8 engines, heavy duty 4WDs and most engines over 400 HP.

Kit contents:

- 1x EWP@150 alloy
- 1x EWP@ Basic wiring harness
- 2x Hose clamps
- 1x RED - Wire joiner
- 1x RED - 6mm ring terminal
- 1x RELAY - 12V 40 Amp 5 Pin W/- resistor protection
- 1x SCREW - SELF TAP 8X3/8 BZ

Code	Max Flow rate	Material	Voltage	Max current	Operating Temperature	Weight	Max pressure	Fits hose sizes	Motor life	EWP Fan Digital controller
EWP8060	162 l/min at 13V DC	Aluminium	3V - 15V DC	10A	-40 °C / +120 °C	1170 g	500 kPa (72,5 PSI)	38 - 51 mm	3000 h continuous at 80°C 12V DC - 7000 h with EWP Fan digital controller	No

OTHER COMPONENTS



Oil and oil vapour from the engine breather pipes are usually fed back into the intake system to be burned off. On a performance or race car this is not ideal as tuned engines can produce more vapour which could diminish performance. The solution to this is to fit an oil catch tank...

These high quality alloy catch tanks from Mocal are designed to be fitted to the inner wing or bulkhead and have 2 x 13mm (1/2") outlets to connect the engine breather pipes to. The special cap allows the tank to breathe without oil bypassing and a sight gauge (not included) on the side lets you know when it's time to empty the tank via the drain plug in the bottom.

For ease of fitment, the tank inlets can be fitted to either side of the tank with the use of the supplied blanking plugs. Available in 1, 2 or 3 litre capacities and in a range of finishes.

Dimensions -

- 1 Litre : 115mm high, 132mm wide (inc flange), 88mm deep
- 2 Litre : 220mm high, 132mm wide (inc flange), 88mm deep
- 3 Litre : 235mm high, 154mm wide (inc flange), 104mm deep

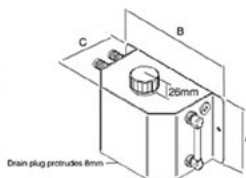

follows

Code	Capacity	Colour	Material	Dimensions A-B-C
CT2	2 L	Aluminium	Brushed aluminium	220x132x88 mm
CT2BLUE	2 L	Blue	Anodized aluminium	220x132x88 mm
CT2C	2 L	Chrome	Aluminium	220x132x88 mm
CT2GOLD	2 L	Gold	Anodized aluminium	220x132x88 mm
CT2BLACK	2 L	Powder black	Aluminium	220x132x88 mm
CT2RED	2 L	Red	Anodized aluminium	220x132x88 mm
CT8	3 L	Aluminium	Brushed aluminium	235x154x104 mm
CT8BLUE	3 L	Blue	Anodized aluminium	235x154x104 mm
CT8BLACK	3 L	Powder black	Aluminium	235x154x104 mm
CT8RED	3 L	Red	Anodized aluminium	235x154x104 mm



Water Cooler Caps

MotoRad radiator caps are designed for the cooling systems of racing cars. Available with three levels of resistance to pressure.

Code	Pressure	Size
T20	18-22 PSI	Standard (car)
T22	20-22 PSI	Standard (car)
T45	28-32 PSI	Standard (car)

Code	Capacity	Colour	Material	Dimensions A-B-C
CT3	1 L	Aluminium	Brushed aluminium	115x132x88 mm
CT3BLUE	1 L	Blue	Anodized aluminium	115x132x88 mm
CT3C	1 L	Chrome	Aluminium	115x132x88 mm
CT3GOLD	1 L	Gold	Anodized aluminium	115x132x88 mm
CT3BLACK	1 L	Powder black	Aluminium	115x132x88 mm
CT3RED	1 L	Red	Anodized aluminium	115x132x88 mm



Water cooler Necks

Radiator cap collars are made of light alloy HE 30. FN-001 with removable outlet

Code	Scope	Outlet Diameter
FN-001	Cars	8 mm